

NOTES:

1. The detectable warning shall be provided by truncated domes.
2. Curb ramps are to be located as shown on the plans or as directed by the engineer. They are to be provided at the intersections wherever an accessible route within the right-of-way of a highway facility crosses a curb regardless of whether sidewalk is existing, proposed or nonexistent. They must be located within pedestrian crosswalks as shown on plans or as directed by the engineer, and should not be located behind vehicle stop lines, existing light poles, fire hydrants, drop inlets, etc. Accessible routes provide a continuous unobstructed, stable, firm and slip resistant path connecting all accessible elements of a facility that can be approached, entered and used by pedestrians.
3. Typical concrete sidewalk is 4" thick. When the entrance radii cannot accommodate the turning requirements of anticipated heavy truck traffic, refer to standard R-7, commercial entrance (Heavy Truck Traffic) for concrete depth.
4. When curb ramps are used in conjunction with a shared use path, the minimum width shall be the width of the shared use path.
5. Install Truncated Dome 3-4" inches from back of curb.

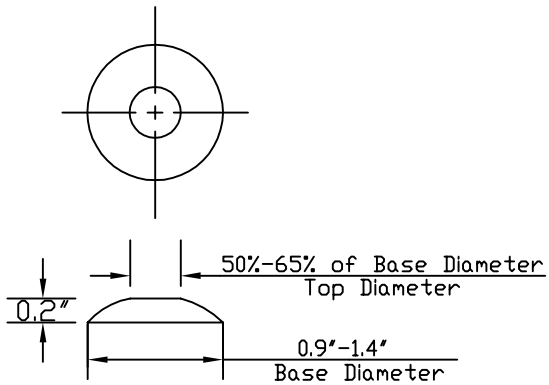

Truncated Dome Detail
Color: Red